



STET 
FLORESTAL

2022

DESTROÇADORES FLORESTAIS



**FLORESTAL
2022**

INDÍCE

DE 5 - 19

DESTROÇADOR HIDRÁULICO PARA ESCAVADORAS

DHL-3	7
DHL-5.5	8
DHL-8	9
DHL-9	10
DHL-13	12
DHF-13	13
DHL-16	14
DHF-16	15
DHL-20	16
DHF-20	17
DHL-30	18
DHF-30	19

DE 21 - 24

DESTROÇADOR HIDRÁULICO PARA CARREGADORAS COMPACTAS

DHC-90	22
DHCL-120	23
DHCF-120	24

DE 27 - 29

DESTROÇADORES FLORESTAIS

DF-180	28
DF-280	29

DE 31 - 38

TRITURADORES FLORESTAIS

TF120	32
TF120	33
TF160	34
TF200	35
TF175	36
TF250	37
TF300	38

DE 41 - 42

FRESADORES FLORESTAIS

FF300	42
-------	----

DE 45 - 59

BRAÇOS DESTROÇADORES

BD35	46
BD70	48
BD70	50
BD90	52
BD100	54
BD140	56

DE 60- 61

PEÇAS DE CORTE

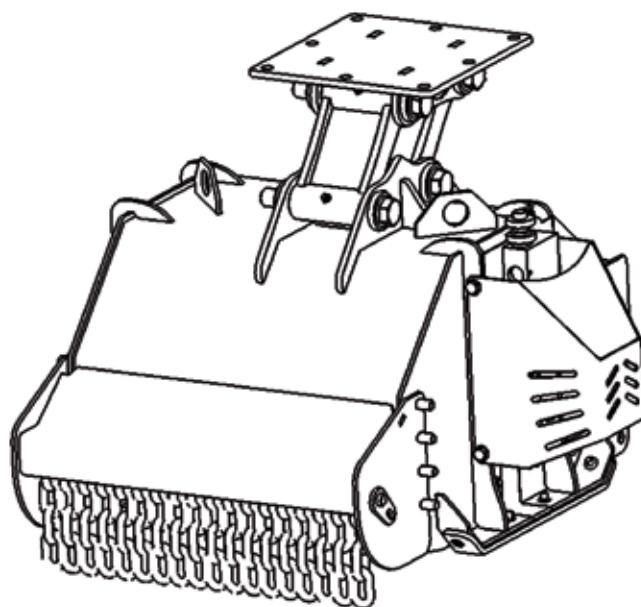

DESTROÇADOR HIDRÁULICO PARA ESCAVADORAS

HBC / Hydraulic Block Control



O QUE INCLUÍ

- Sistema anti-cavitação; para travagem progressiva da inércia do rotor.
- Dispositivo de limitação de pressão; para proteção de bombas e motores.
- Bloco de válvulas limitadoras de caudal.

De serie em todos os modelos

MOD.	HBC
DHL-3	mod. A
DHL-5.5	mod. B
DHL-8	mod. C
DHL-9	mod. C
DHO-13	mod. D
DHF-13	mod. D
DHL-16	mod. D
DHF-16	mod. D
DHL-20	mod. D
DHF-20	mod. D
DHFL-30	mod. E
DHC-90	mod. C
DHC-90 (200)	mod. D
DHCL-120	mod. D
DHCF-120	mod. D

MOD.	L/MIN MAX
A	50 l/min
B	90 l/min
C	150 l/min
D	240 l/min
E	280 l/min

DHL-3**EQUIPAMENTO DE SÉRIE**

- Transmissão direta ao rotor.
- Rotor helicoidal com martelos ou lâminas (especificar no pedido).
- Tampa de proteção do motor hidráulico.
- Motor redutor hidráulico de alumínio, com drenagem.
- Sistema HBC (Hydraulic Block Control) mod A.
- Rolo traseiro regulável em altura Ø140 mm.
- Skids de apoio com peças substituíveis em material anti desgaste.
- Saia traseira protetora ajustável.
- Correntes de proteção frontal para evitar impactos.
- Braços auto nivelantes.
- Placa com furos preparados para engatar.
- Mangueiras hidráulicas com tampas de 1500 mm de comprimento.
- Proteções para evitar acidentes de acordo com as normas CE.

MOD.**DHL-3/60****DHL-3/80**

Destroçador hidráulico para miniescavadoras de 2 a 3 toneladas. Ideal para limpar relva ou pequenos arbustos até 2 cm de diâmetro.

ACESSÓRIOS

Peça de engate à medida, com pinos

Motor sem drenagem
(máx. 12 bar pressão no retorno)



MOD.	MM	KG	Nº	Nº	CC	L / MIN	BAR	CM	TN	MM	MM	MM
DHL-3/60	600	158	9	16+8	15	35	200	2	2-3	900	780	640
DHL-3/80	800	185	12	24+12	15	35	200	2	2-3	1100	780	640

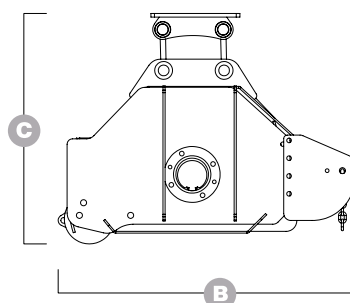
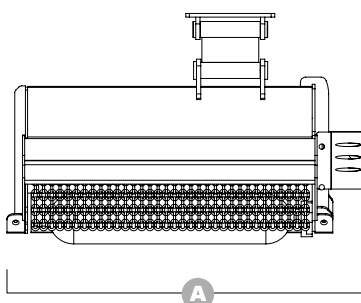
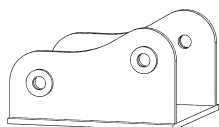

DHL-5.5**EQUIPAMENTO DE SERIE**

- Transmissão lateral por correias tipo B.
- Rotor helicoidal com martelos ou lâminas (especificar no pedido).
- Fila de contra-martelos em "U".
- Tampa de proteção do motor hidráulico.
- Motor hidráulico de fundição de engrenagens, com drenagem.
- Sistema HBC (Hydraulic Block Control) mod B.
- Rolo traseiro regulável em altura Ø140 mm.
- Skids de apoio com peças substituíveis em material anti desgaste.
- Saia traseira protetora ajustável.
- Correntes de proteção frontal para evitar impactos.
- Braços auto nivelantes.
- Placa com furos preparados para engatar.
- Mangueiras hidráulicas com tampas de 1500 mm de comprimento.
- Proteções para evitar acidentes de acordo com as normas CE.

ACESSÓRIOS

Peça de engate à medida, com pinos

Motor unidirecional sem drenagem
(máx. 12 bar pressão de retorno)

Suplemento HBC de tipo B a tipo C

MOD.

DHL-5.5/80

DHL-5.5/100

Destroçador hidráulico para miniescavadoras de 3,5 a 5,5 toneladas. Ideal para limpar relva e triturar arbustos e ramos até 4 cm de diâmetro.



MOD.	MM	KG	Nº	Nº	CC	Nº	L / MIN	BAR	CM	TN	MM	MM	MM
DHL-5.5/80	800	250	12	24+12	20	2	45	200	4	3,5-5,5	980	900	600
DHL-5.5/100	1000	275	16	32+16	20	2	45	200	4	3,5-5,5	1180	900	600

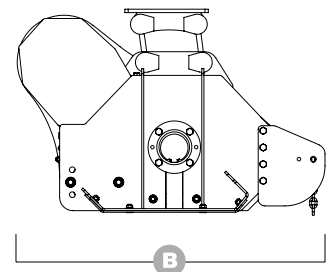
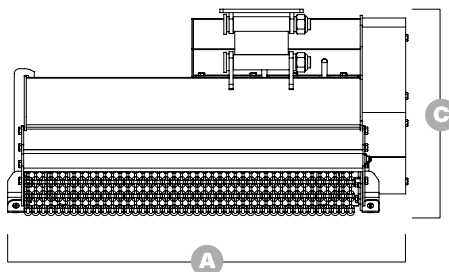
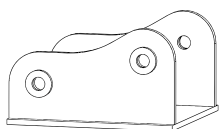

DHL-8



EQUIPAMENTO DE SÉRIE

- Transmissão lateral por correias tipo B.
- Rotor helicoidal com martelos ou lâminas (especificar no pedido).
- Fila de contra-martelos em "U".
- Tampa de proteção do motor hidráulico.
- Motor redutor hidráulico fundido, com drenagem.
- Sistema HBC (Hydraulic Block Control) mod C.
- Rolo traseiro regulável em altura Ø140 mm.
- Skids de apoio com peças substituíveis em material anti desgaste.
- Saia traseira protetora ajustável.
- Correntes de proteção frontal para evitar impactos.
- Braços auto nivelantes.
- Placa com furos preparados para engatar.
- Mangueiras hidráulicas com tampas de 1500 mm de comprimento.
- Proteções para evitar acidentes de acordo com as normas CE.

ACESSÓRIOS

Peça de engate à medida, com pinos

Motor unidirecional sem drenagem
(máx. 12 bar pressão de retorno)

Suplemento HBC de tipo C a tipo D

MOD.

DHL-8/80

DHL-8/100

DHL-8/120

Destroçador hidráulica para escavadoras de 5,5 a 8 toneladas. Ideal para limpar relva e triturar arbustos e ramos até 5 cm de diâmetro.



MOD.	MM	KG	Nº	Nº	CC	Nº	L / MIN	BAR	CM	TN	MM	MM	MM
DHL-8/80	800	365	12	24+12	26	2	65	220	5	5,5-8	970	860	850
DHL-8/100	1000	415	16	32+16	26	2	65	220	5	5,5-8	1170	860	850
DHL-8/120	1200	470	18	36+18	26	2	65	220	5	5,5-8	1370	860	850

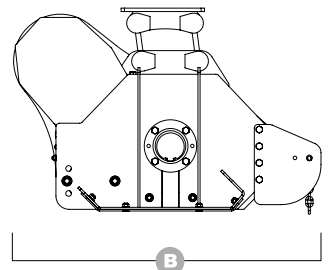
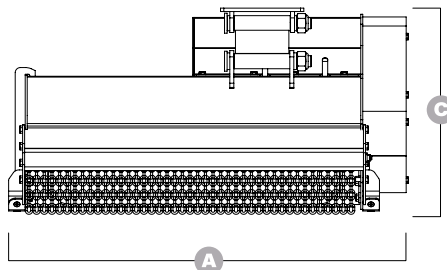
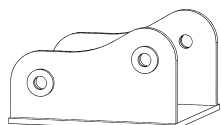

DHL-9**MOD.**

DHL-9/80

DHL-9/100

DHL-9/120

Destroçador hidráulico para escavadoras de 7 a 9 toneladas. Ideal para limpar relva e triturar arbustos e ramos até 5 cm de diâmetro.

EQUIPAMENTO DE SÉRIE

- Transmissão lateral por correias tipo B.
- Rotor de martelo ou lâmina (especificar no pedido).
- Fila de contra-martelos em "U"
- Tampa de proteção do motor hidráulico.
- Moto redutor hidráulico fundido, com drenagem.
- Sistema HBC (Hydraulic Block Control) mod C.
- Rolo traseiro regulável em altura Ø165 mm.
- Skids de apoio com peças substituíveis em material anti desgaste.
- Saia traseira protetora ajustável.
- Correntes de proteção frontal para evitar impactos.
- Placa com furos preparados para engatar.
- Mangueiras hidráulicas com tampas de 1500 mm de comprimento.
- Proteções para evitar acidentes de acordo com as normas CE

ACESSÓRIOS

Peça de engate à medida, com pinos

Motor unidirecional sem drenagem
(máx. 12 bar pressão de retorno)

Suporte autonivelante para peça de engate

Engate rápido à medida

Suplemento HBC de tipo C a tipo D



MOD.	MM	KG	Nº	Nº	CC	Nº	L / MIN	BAR	CM	TN	MM	MM	MM
DHL-9/80	800	355	8	16+8	36	3	80	220	6	7-9	970	860	630
DHL-9/100	1000	405	10	20+10	36	3	80	220	6	7-9	1170	860	630
DHL-9/120	1200	460	12	24+12	36	3	80	220	6	7-9	1370	860	630

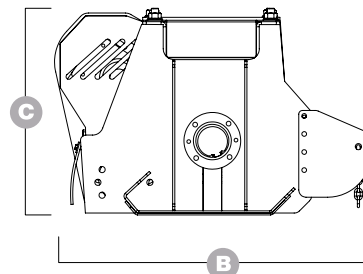
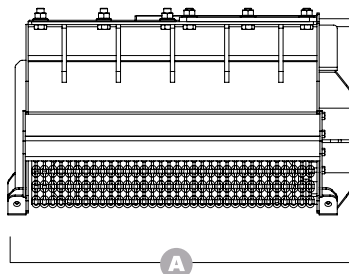
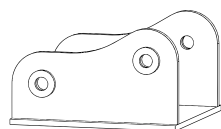

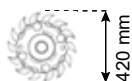
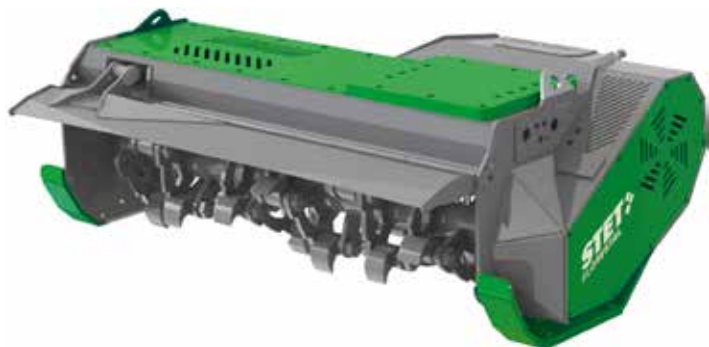

DHL-13**MOD.****DHL-13/100****DHL-13/120****DHL-13/140**

Destroçador hidráulico para escavadoras de 8 a 13 toneladas.
Ideal para triturar todo o tipo de material vegetal: relva, arbustos e ramos até 15 cm de diâmetro.

EQUIPAMENTO DE SÉRIE

- Transmissão lateral por correias dentadas tipo B.
- Rotor de martelo florestal.
- Duas fileiras de contra-martelos em "U".
- Tampa de proteção do motor hidráulico.
- Motor de pistão axial de deslocamento variável com drenagem.
- Sistema HBC (Hydraulic Block Control) mod D.
- Juntas sem pontos de graxa, com buchas auto lubrificantes.
- Skids de apoio com peças substituíveis em material anti desgaste.
- Capô traseiro articulado.
- Correntes de proteção frontal para evitar impactos.
- Placa com furos preparados para engatar.
- Mangueiras hidráulicas com tampas de 1500 mm de comprimento.
- Proteções para evitar acidentes de acordo com as normas CE.

ACESSÓRIOS

* Peça de engate à medida, com pinos

Engate rápido à medida**Porta traseira hidráulica****Suplemento distribuidor elétrico para abertura de porta com betoneira**

MOD.	MM	KG	Nº	Nº	CC	L/MIN	BAR	CM	TN	MM	MM	MM
DHL-13/100	1000	460	18	4	35/46	85/110	250	14	8-13	1350	860	650
DHL-13/120	1200	530	22	4	35/46	85/110	250	14	8-13	1550	860	650
DHL-13/140	1400	600	26	4	35/46	85/110	250	14	8-13	1750	860	650

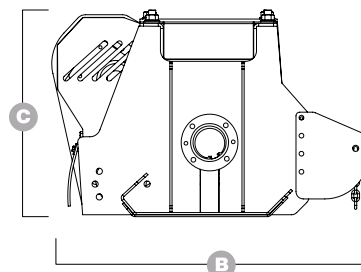
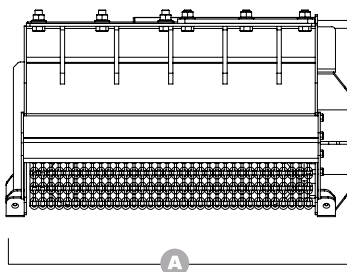
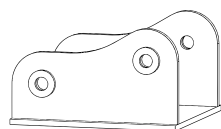

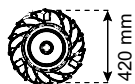
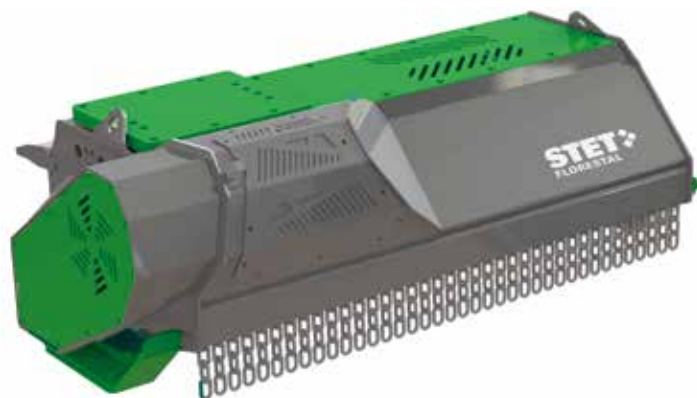
DHF-13**MOD.****DHF-13/100****DHF-13/120****DHF-13/140**

Destroçador hidráulico para escavadoras de 8 a 13 toneladas.
Ideal para triturar todo o tipo de material vegetal: relva, arbustos e ramos até 15 cm de diâmetro.

EQUIPAMENTO DE SÉRIE

- Transmissão lateral por correias dentadas tipo B.
- Rotor de martelos fixos com ponta de vidia.
- Duas fileiras de contra-martelos em "U".
- Tampa de proteção do motor hidráulico.
- Motor de pistão axial de deslocamento variável com drenagem.
- Sistema HBC (Hydraulic Block Control) mod D.
- Juntas sem pontos de graxa, com buchas auto lubrificantes.
- Skids de apoio com peças substituíveis em material anti desgaste.
- Capô traseiro articulado.
- Correntes de proteção frontal para evitar impactos.
- Placa com furos preparados para engatar.
- Mangueiras hidráulicas com tampas de 1500 mm de comprimento.
- Proteções para evitar acidentes de acordo com as normas CE

ACESSÓRIOS

* Peça de engate à medida, com pinos

Engate rápido à medida**Porta traseira hidráulica****Suplemento distribuidor elétrico para abertura de porta com betoneira**

MOD.	MM	KG	Nº	Nº	CC	L/MIN	BAR	CM	TN	MM	MM	MM
DHF-13/100	1000	505	18	4	35/46	85/110	250	14	8-13	1350	860	650
DHF-13/120	1200	570	21	4	35/46	85/110	250	14	8-13	1550	860	650
DHF-13/140	1400	640	27	4	35/46	85/110	250	14	8-13	1750	860	650

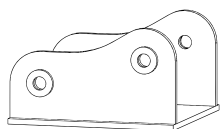

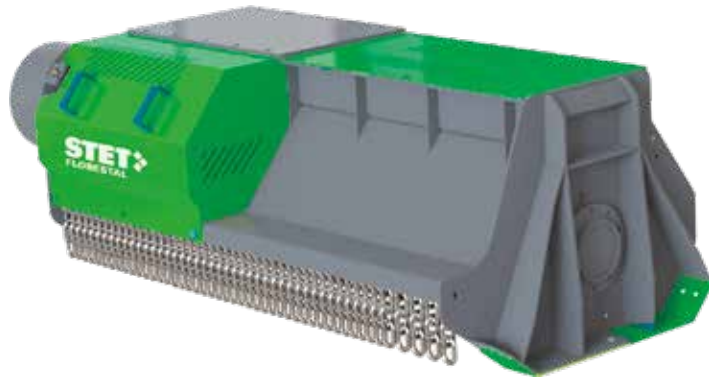
DHL-16**EQUIPAMENTO DE SÉRIE**

- Transmissão lateral por correias dentadas tipo B.
- Rotor de martelo florestal.
- Duas fileiras de contra-martelos em "U".
- Tampa de proteção do motor hidráulico.
- Motor de pistão hidráulico, com drenagem.
- Sistema HBC (Hydraulic Block Control) mod D.
- Skids de apoio com peças substituíveis em material anti desgaste.
- Capô traseiro articulado.
- Correntes de proteção frontal para evitar impactos.
- Placa com furos preparados para engatar.
- Mangueiras hidráulicas com tampas de 1500 mm de comprimento.
- Proteções para evitar acidentes de acordo com as normas CE.

ACESSÓRIOS

* Peça de engate à medida, com pinos

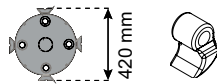
**MOD.****DHL-16/100****DHL-16/120****DHL-16/140**

Destroçador hidráulico para escavadoras de 12 a 16 toneladas.
Ideal para triturar todo o tipo de material vegetal: relva, arbustos e ramos até 12 cm de diâmetro.

Engate rápido à medida

MOD.	MM	KG	Nº	Nº	CC	L/MIN	BAR	CM	TN	MM	MM	MM
DHL-16/100	1000	635	16	4	45	110	280	12	12-16	1350	860	650
DHL-16/120	1200	705	20	4	45	110	280	12	12-16	1550	860	650
DHL-16/140	1400	785	24	4	45	110	280	12	12-16	1750	860	650

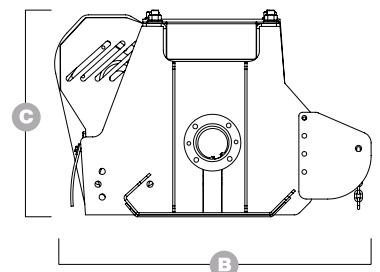
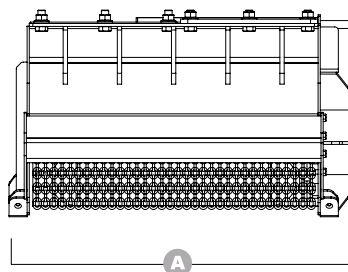
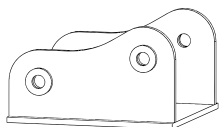

DHF-16



EQUIPAMENTO DE SÉRIE

- Transmissão lateral por correias dentadas tipo B.
- Rotor de martelos fixos com ponta de vidia.
- Duas fileiras de contra-martelos em "U".
- Tampa de proteção do motor hidráulico.
- Motor de pistão hidráulico, com drenagem.
- Sistema HBC (Hydraulic Block Control) mod D.
- Skids de apoio com peças substituíveis em material anti desgaste.
- Capô traseiro articulado.
- Correntes de proteção frontal para evitar impactos.
- Placa com furos preparados para engatar.
- Mangueiras hidráulicas com tampas de 1500 mm de comprimento.
- Proteções para evitar acidentes de acordo com as normas CE.

ACESSÓRIOS

* Peça de engate à medida, com pinos



MOD.

DHF-16/100

DHF-16/120

DHF-16/140

Destroçador hidráulico para escavadoras de 12 a 16 toneladas. Ideal para triturar todo o tipo de material vegetal: erva, arbustos e ramos até 15 cm de diâmetro.

Engate rápido à medida



MOD.	MM	KG	Nº	Nº	CC	L/MIN	BAR	CM	TN	MM	MM	MM
DHF-16/100	1000	675	18	4	45	110	280	15	12-16	1350	860	650
DHF-16/120	1200	745	21	4	45	110	280	15	12-16	1550	860	650
DHF-16/140	1400	815	27	5	45	110	280	15	12-16	1750	860	650

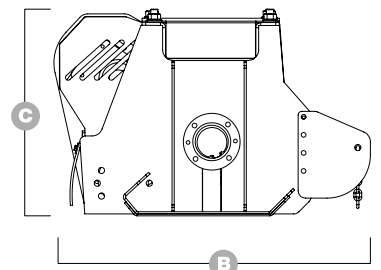
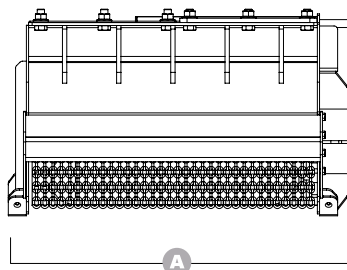
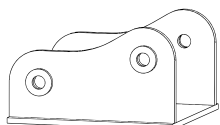

DHL-20



EQUIPAMENTO DE SÉRIE

- Transmissão lateral por correias dentadas tipo B.
- Rotor de martelo florestal.
- Duas fileiras de contra-martelos em "U".
- Tampa de proteção do motor hidráulico.
- Motor de pistão hidráulico, com drenagem.
- Sistema HBC (Hydraulic Block Control) mod D.
- Skids de apoio com peças substituíveis em material anti desgaste.
- Capô traseiro com dobradiças e saia protetora.
- Correntes de proteção frontal para evitar impactos.
- Placa com furos preparados para engatar.
- Mangueiras hidráulicas com tampas de 1500 mm de comprimento.
- Proteções para evitar acidentes de acordo com as normas CE.

ACESSÓRIOS

* Peça de engate à medida, com pinos.

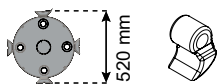

MOD.
DHL-20/100
DHL-20/120
DHL-20/140

Engate rápido à medida

Destroçador hidráulico para escavadoras de 15 a 20 toneladas. Ideal para triturar todo o tipo de material vegetal: relva, arbustos, ramos e troncos até 20 cm de diâmetro.



MOD.	MM	KG	Nº	Nº	CC	L/MIN	BAR	CM	TN	MM	MM	MM
DHL-20/100	1000	791	16	4	56	135	300	20	15-20	1450	914	750
DHL-20/120	1200	897	20	4	56	135	300	20	15-20	1650	914	750
DHL-20/140	1400	1003	24	5	56	135	300	20	15-20	1850	914	750

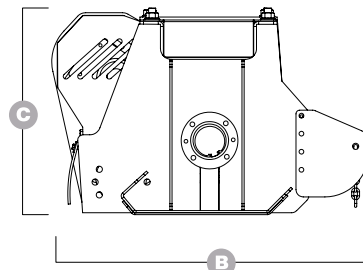
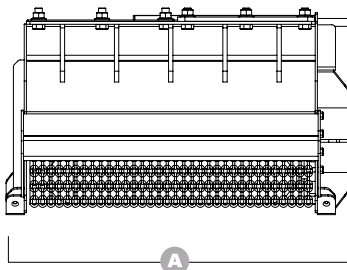
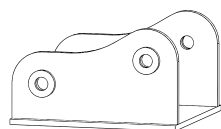

DHF-20



EQUIPAMENTO DE SÉRIE

- Transmissão lateral por correias dentadas tipo B.
- Rotor de martelos fixos com ponta de vidia.
- Duas fileiras de contra-martelos em "U".
- Tampa de proteção do motor hidráulico.
- Motor de pistão hidráulico, com drenagem.
- Sistema HBC (Hydraulic Block Control) mod D.
- Skids de apoio com peças substituíveis em material anti desgaste.
- Capô traseiro articulado.
- Correntes de proteção frontal para evitar impactos.
- Placa com furos preparados para engatar.
- Mangueiras hidráulicas com tampas de 1500 mm de comprimento.
- Proteções para evitar acidentes de acordo com as normas CE.

ACESSÓRIOS

* Peça de engate à medida, com pinos



Engate à medida

MOD.

DHF-20/100

DHF-20/120

DHF-20/140

Destroçador hidráulico para escavadoras de 15 a 20 toneladas. Ideal para triturar todo o tipo de material vegetal: relva, arbustos, ramos e troncos até 25 cm de diâmetro.



MOD.	MM	KG	Nº	Nº	CC	L/MIN	BAR	CM	TN	MM	MM	MM
DHF-20/100	1000	789	18	5	56	135	300	25	15-20	1450	914	750
DHF-20/120	1200	982	24	5	56	135	300	25	15-20	1650	914	750
DHF-20/140	1400	1086	27	5	56	135	300	25	15-20	1850	914	750

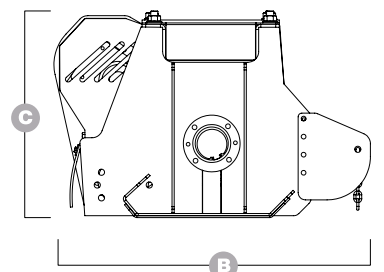
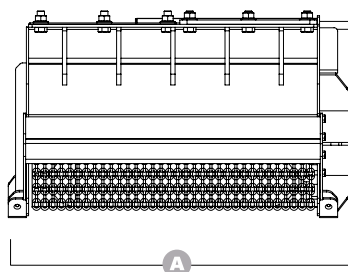
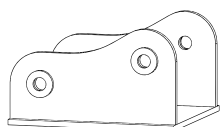

DHL-30**EQUIPAMENTO DE SÉRIE**

- Transmissão lateral por correias dentadas tipo B.
- Rotor de martelo florestal.
- Duas fileiras de contra-martelos em "U".
- Tampa de proteção do motor hidráulico.
- Motor de pistão hidráulico, com drenagem.
- Sistema HBC (Controle de Bloco Hidráulico) Mod. D (DHL-30/120) e Mod. E (DHL-30/140, DHL-30/160).
- Skids de apoio com peças substituíveis em material anti desgaste.
- Capô traseiro articulado.
- Correntes de proteção frontal para evitar impactos.
- Placa com furos preparados para engatar.
- Mangueiras hidráulicas com tampas de 1500 mm de comprimento.
- Proteções para evitar acidentes de acordo com as normas CE.

ACESSÓRIOS

* Peça de engate à medida, com pinos.

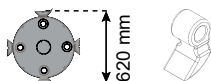
**MOD.****DHL-30/120****DHL-30/140****DHL-30/160**

Destroçador hidráulico para escavadoras de 18 a 30 toneladas. Ideal para triturar todo o tipo de material vegetal: relva, arbustos, ramos e troncos até 30 cm de diâmetro.

Engate à medida

MOD.	MM	KG	Nº	Nº	CC	L/MIN	BAR	CM	TN	MM	MM	MM
DHL-30/120	1200	1015	20	5	56	140	300	30	18-30	1660	930	835
DHL-30/140	1400	1148	24	5	72	190	300	30	18-30	1860	930	835
DHL-30/160	1600	1281	28	5	72	190	300	30	18-30	2060	930	835

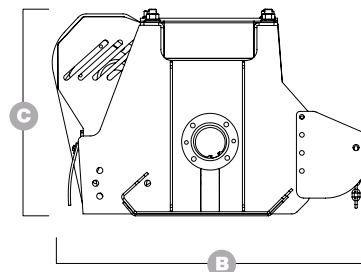
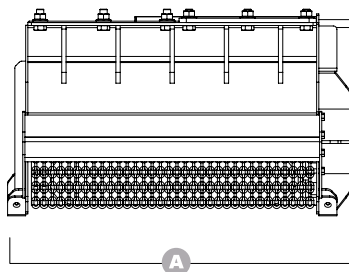
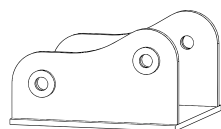

DHF-30



EQUIPAMENTO DE SÉRIE

- Transmissão lateral por correias dentadas tipo B.
- Rotor de martelos fixos com ponta de vidia.
- Duas fileiras de contra-martelos em "U".
- Tampa de proteção do motor hidráulico.
- Motor de pistão hidráulico, com drenagem.
- Sistema HBC (Hydraulic Block Control) mod E.
- Skids de apoio com peças substituíveis em material anti desgaste.
- Capô traseiro articulado.
- Correntes de proteção frontal para evitar impactos.
- Placa com furos preparados para engatar.
- Mangueiras hidráulicas com tampas de 1500 mm de comprimento.
- Proteções para evitar acidentes de acordo com as normas CE.

ACESSÓRIOS

* Peça de engate à medida, com pinos.

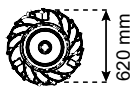

MOD.

DHF-30/120

DHF-30/140

DHF-30/160

Destroçador hidráulico para escavadoras de 20 a 35 toneladas. Ideal para triturar todo o tipo de material vegetal: relva, arbustos, ramos e troncos até 40 cm de diâmetro.

Engate à medida



MOD.	MM	KG	Nº	Nº	CC	L/MIN	BAR	CM	TN	MM	MM	MM
DHF-30/120	1200	1167	21	5	72	190	300	40	20-35	1660	930	835
DHF-30/140	1400	1304	27	5	72	190	300	40	20-35	1860	930	835
DHF-30/160	1600	1440	33	5	72	190	300	40	20-35	2060	930	835

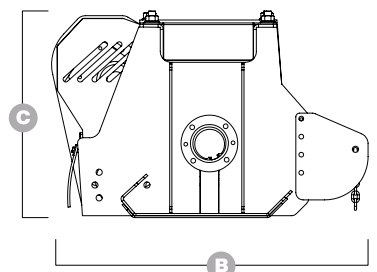
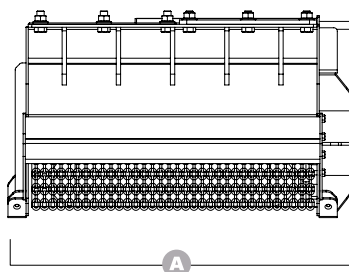
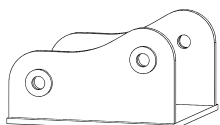

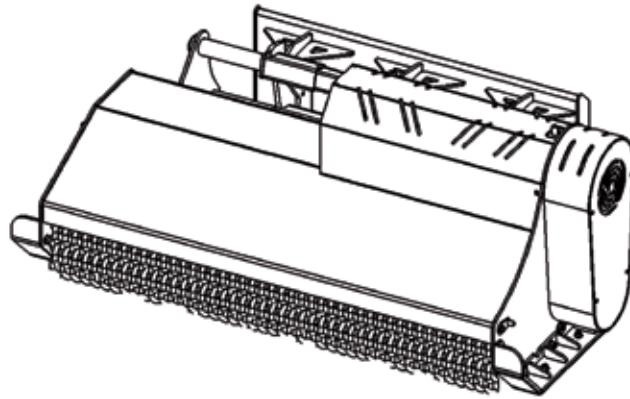

DESTROÇADOR PARA CARREGADORAS COMPACTAS

DHC-90

MOD.

DHC-90/130

DHC-90/140

DHC-90/160

DHC-90/180

DHC-90/200

Destroçador para carregadoras compactas de 50 a 90 CV. Ideal para triturar erva, arbustos e troncos entre 5-6 cm diâmetro.



MOD.	MM	KG	Nº	Nº	CC	Nº	L/MIN	BAR	CM	CV	MM	MM	MM
DHC-90/130	1300	650	14	28+14	31	3	65	200	5-6	50-90	1493	1365	767
DHC-90/140	1400	665	14	28+14	31	3	65	200	5-6	50-90	1693	1365	767
DHC-90/160	1600	690	16	32+16	41	3	90	220	5-6	50-90	1893	1365	767
DHC-90/180	1800	745	20	40+20	41	3	90	220	5-6	50-90	2093	1365	767
DHC-90/200	2000	790	22	44+22	56	3	110	220	5-6	50-90	2293	1365	767

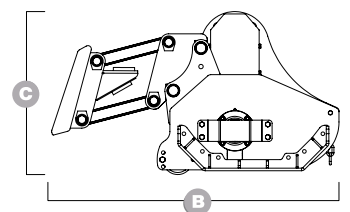
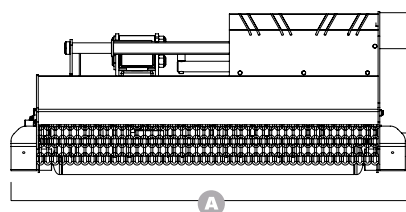

* Neste caso a carregadora deve estar equipada com distribuidor simples efeito + linha de drenagem (para o motor e para o destroçador) e um distribuidor de duplo efeito (para o deslocamento hidráulico).

EQUIPAMENTO DE SÉRIE

- Engate universal (SAE J2513).
- Transmissão lateral por correias tipo B.
- Rotor de martelo ou lâmina (especificar no pedido).
- Fila de contra-martelos em "U".
- Tampa de proteção do motor hidráulico.
- Motor de fundição de engrenagem hidráulica, com drenagem.
- Sistema HBC (Hydraulic Block Control) Mod. C (de DHC-90/130 a DHC-90/180) e Mod. D (DHC-90/200).
- Rolo traseiro regulável em altura Ø165 mm.
- Skids de apoio com peças substituíveis em material anti desgaste.
- Correntes de proteção frontal para evitar impactos.
- Mangueiras hidráulicas com tampas de 1500 mm de comprimento.
- Proteções para evitar acidentes de acordo com as normas CE.

ACESSÓRIOS**Engate oscilante****Deslocamento hidráulico com mangueiras e engates rápidos****Suplemento HBC de tipo C a tipo D**

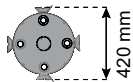
DHCL-120**EQUIPAMENTO DE SÉRIE**

- Engate fixo universal (SAE J2513) para carregadeira compacta.
- Transmissão lateral por correias tipo C.
- Rotor de martelo florestal.
- Duas fileiras de contra-martelos em "U".
- Tampa de proteção do motor hidráulico.
- Motor de pistão hidráulico, com drenagem.
- Sistema HBC (Hydraulic Block Control) mod D.
- Barra de proteção traseira fixa.
- Skids de apoio com peças substituíveis em material anti desgaste.
- Portão frontal hidráulico.
- Indicador de controle de pressão de trabalho.
- Mangueiras hidráulicas com tampas de 1500 mm de comprimento.
- Proteções para evitar acidentes de acordo com as normas CE.

ACESSÓRIOS

Suplemento distribuidor elétrico para abertura de porta com betoneira

MOD.

DHCL-120/140

DHCL-120/160

DHCL-120/180

Destroçador hidráulico para carregadoras compactas de 70 a 120 CV. Ideal para triturar relva, arbustos e troncos até 12 cm de diâmetro.



MOD.	MM	KG	Nº	Nº	CC	L / MIN	BAR	CM	CV	MM	MM	MM
DHCL-120/140	1400	1082	24	4	56	115	245	12	70-120	1740	923	1550
DHCL-120/160	1600	1150	28	4	56	115	245	12	70-120	1940	923	1550
DHCL-120/180	1800	1218	32	4	56	115	245	12	70-120	2140	923	1550

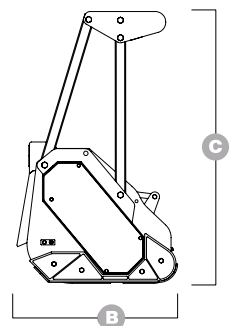
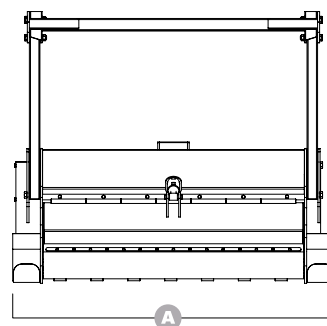

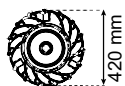
DHCF-120**EQUIPAMENTO DE SÉRIE**

- Engate fixo universal (SAE J2513) para carregadora compacta.
- Transmissão lateral por correias tipo C.
- Rotor de martelo fixo com ponta de wídia.
- Duas fileiras de contra-martelos em "U".
- Tampa de proteção do motor hidráulico.
- Motor de pistão hidráulico, com drenagem.
- Sistema HBC (Hydraulic Block Control) mod D.
- Barra de proteção traseira fixa.
- Skids de apoio com peças substituíveis em material anti desgaste.
- Portão frontal hidráulico.
- Indicador de controle de pressão de trabalho.
- Mangueiras hidráulicas com tampas de 1500 mm de comprimento.
- Proteções para evitar acidentes de acordo com as normas CE.

MOD.

DHCF-120/140

DHCF-120/160

DHCF-120/180

Destroçador hidráulico para carregadoras compactas de 70 a 120 CV. Ideal para triturar erva, arbustos e troncos até 15 cm de diâmetro.

ACESSÓRIOS

Suplemento distribuidor elétrico para abertura de porta com betoneira



MOD.	MM	KG	Nº	Nº	CC	L / MIN	BAR	CM	CV	MM	MM	MM
DHCF-120/140	1400	1057	36	4	56	115	245	15	70-120	1740	923	1550
DHCF-120/160	1600	1161	42	4	56	115	245	15	70-120	1940	923	1550
DHCF-120/180	1800	1173	42	4	56	115	245	15	70-120	2140	923	1550

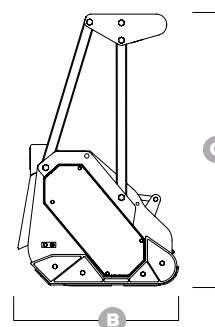
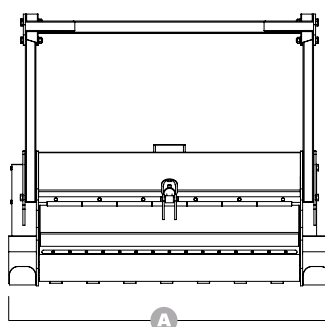

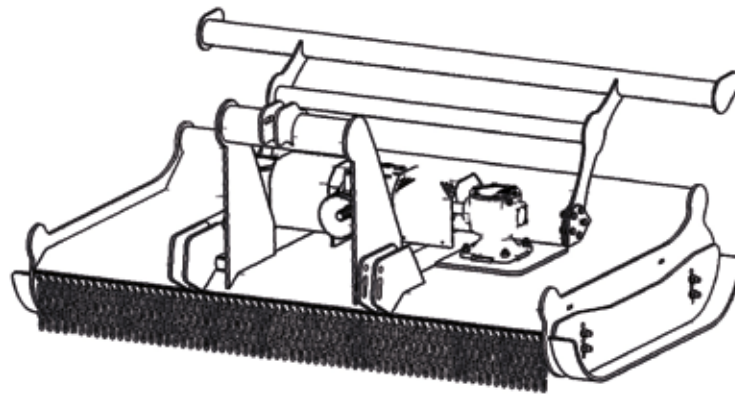

DESTROÇADORES FLORESTAIS

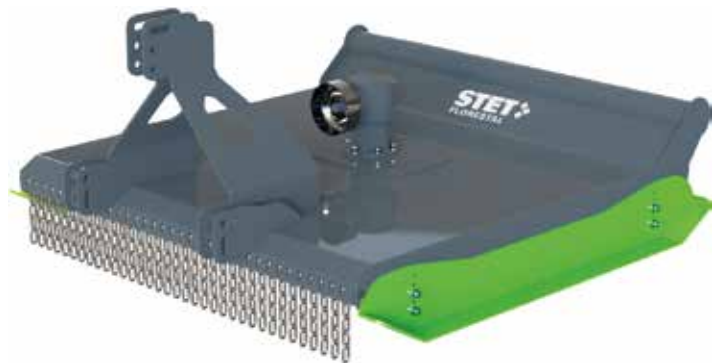
DF-180**EQUIPAMENTO DE SÉRIE**

- Grupo multiplicador muito resistente 100 CV.
- Engate fixo CAT II
- Cadeias de corte florestal.
- Skids de controle de profundidade.
- Correntes de proteção frontal.
- Cardan com embraiagem.
- Proteções para evitar acidentes de acordo com as normas CE.

ACESSÓRIOS

Porta traseira mecânica

Porta traseira hidráulica

Arrefecedor fixo

Suplemento grupo multiplicador 140CV

MOD.

DF-180/140

DF-180/160

DF-180/180

Destroçador muito robusto para trabalhos florestais para tratores entre 70 e 180 CV.



MOD.	MM	KG	Nº	C.V.	R.P.M.	MM	MM	MM
DF-180/140	1400	620	4	70-110	540	1700	1950	1200
DF-180/160	1600	750	4	80-110	540	1900	2150	1200
DF-180/180	1800	760	4	80-110	540	2100	2350	1200

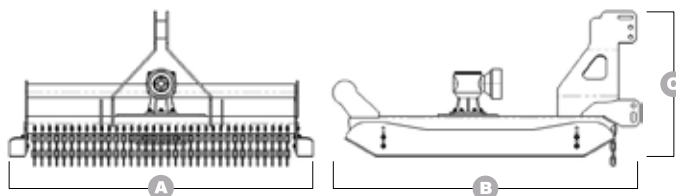

DF-280**EQUIPAMENTO DE SÉRIE**

- Transmissão contra-rotativa por 3 grupos multiplicadores com tampa de proteção.
- Engate fixo CAT II-III
- Sistema de segurança de transmissão entre os grupos multiplicadores com acoplamentos elásticos de torção utilizando elastômeros.
- Cadeias de corte florestal.
- Skids de controle de profundidade.
- Correntes de proteção frontal.
- Cardan com embraiagem.
- Proteções para evitar acidentes de acordo com as normas CE.

ACESSÓRIOS

Porta traseira mecânica

Porta traseira hidráulica

Arrefecedor fixo

Suplemento grupo multiplicador 140CV

MOD.

DF-280/225

DF-280/250

Destroçador muito robusto para trabalhos florestais para tratores entre 120 e 280 CV.



MOD.	MM	KG	Nº	C.V.	R.P.M.	MM	MM	MM
DF-280/225	2250	1650	8	120-200	1000	2550	1950	1200
DF-280/250	2500	1780	8	140-200	1000	2800	2100	1200

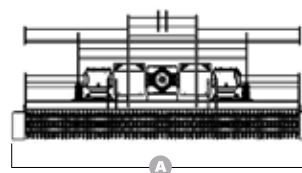

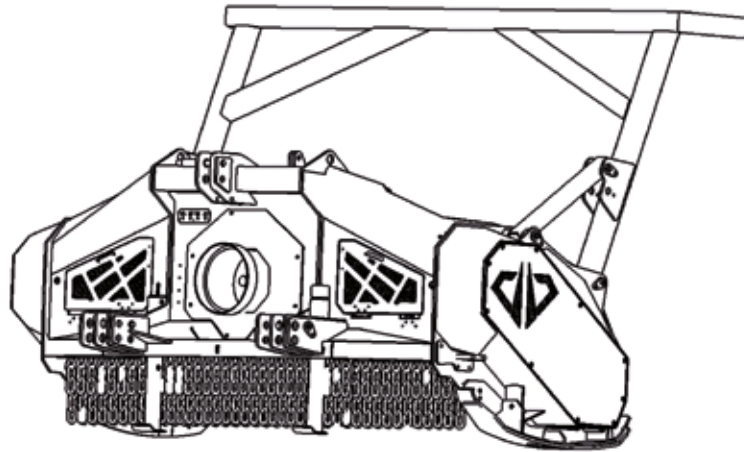

TRITURADORES FLORESTAIS

TF120

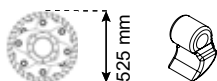

MOD.
TF120/180
TF120/200
TF120/220

Triturador destinado a trabalhos semi-florestais devido às suas características de grande robustez em todos os detalhes da máquina.



MOD.	MM	KG	Nº	C.V	Ø	R.PM	Nº	MM	MM	MM
TF120/180	1800	1100	32	80 – 95	15 cm	540	5	2100	1120	1100
TF120/200	2000	1180	36	95 – 110	15 cm	540	5	2300	1120	1100
TF120/220	2200	1260	40	110 - 125	15 cm	540	5	2500	1120	1100

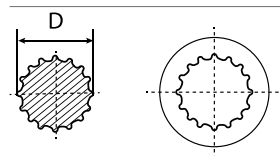

De serie cardan 1"3/8 Z6 - 1"3/4 Z6
Para D=1"3/8 o Z20- Z21
Indicar no pedido

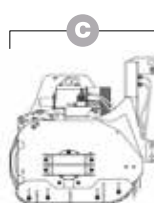
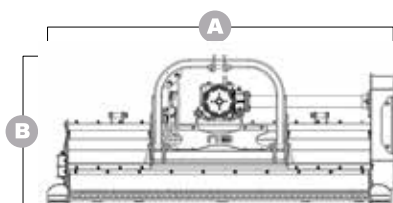

EQUIPAMENTO DE SÉRIE

- Rotor helicoidal aberto altamente versátil com design especial Tanker.
- Chassis muito resistente com reforços interiores.
- Engate fixo centrado CAT II
- Grupo multiplicador com roda livre dupla para poder engatar na frente e atrás do trator.
- Cobertura de proteção robusta da polia soldada ao chassi.
- Cubo externo com proteção.
- 1 linha de contra-martelos de cumeeira aparafusados exclusivos.
- Patins com geometria especial para trabalhar em qualquer tipo de terreno.
- Portão traseiro hidráulico com pistão.
- Transmissão lateral por correias dentadas.
- Tensor de correia especial com terceiro tensor de polia com parafuso.
- Pontos de lubrificação do cubo e do rotor protegidos.
- Juntas sem pontos de graxa, com buchas auto lubrificantes.
- Dupla fileira de correntes frontais e elástico anti projeção.
- Parafusos e cardan.
- Proteção para evitar acidentes de acordo com as normas CE.
- Nota: se especificado no pedido, o multiplicador pode ser preparado para tomadas de força de 1000 rpm (540 rpm como padrão).

ACESSÓRIOS

Barra de proteção traseira fixa

Segunda fila de martelos contra-crista aparafusados

TF120



EQUIPAMENTO DE SÉRIE

- Chassis com carenagem para maior proteção do grupo e da transmissão.
- Rotor de martelos com pontas fixas em ponta de widia
- Engate fixo centrado CAT II.
- Grupo multiplicador altamente robusto com roda livre.
- Chassis altamente resistente ao desgaste.
- 2 fileiras de contra-martelos.
- Patins anti desgaste.
- Porta traseira hidráulica com pistão.
- Transmissão lateral em todos os modelos por correias dentadas tipo B.
- Proteção frontal e traseira com correntes.
- Parafusos e cardan.
- Preparado para tomadas de força do trator a 1000 rpm.
- Proteção para evitar acidentes de acordo com as normas CE.
- Nota: se especificado no pedido, o multiplicador pode ser preparado para tomadas de força de 540 r.p.m.

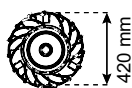

MOD.
TF120/160
TF120/180
TF120/200

ACESSÓRIOS
Barra de proteção traseira fixa
Barra de proteção traseira hidráulica

Triturador destinado ao uso florestal devido às suas características de grande robustez em todos os detalhes da máquina.



MOD.	MM	KG	Nº	C.V	Ø	R.PM	Nº	MM	MM	MM
TF120/160	1600	1145	33	80-120	20	1000	5	2050	950	1000
TF120/180	1800	1165	36	80-120	20	1000	5	2250	950	1000
TF120/200	2000	1255	39	80-120	20	1000	5	2450	950	1000

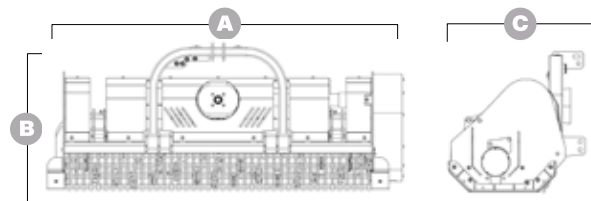
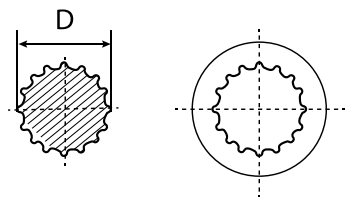

De série cardan 1"3/8 Z6 - 1"3/8 Z6
 Para D=1"3/4 o Z20- Z21 indicar no pedido.

TF160

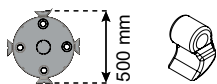

MOD.

TF160/180

TF160/200

TF160/220

Triturador destinada a um uso florestal pelas suas características de grande robustez em todos os detalhes da máquina.

Kit skid com placa inferior em Hardox

Suplemento barra traseira com sistema de parafusos desmontável



MOD.	MM	KG	Nº	C.V	Ø	R.PM	Nº	MM	MM	MM
TF160/180	1800	1850	28	120-130	30	1000	4+4	2360	1480	1175
TF160/200	2000	2000	32	130-140	30	1000	4+4	2560	1480	1175
TF160/220	2200	2150	36	140-160	30	1000	4+4	2760	1480	1175

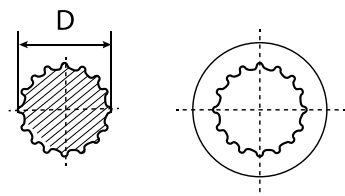

De serie cardan 1"3/8 Z6 - 1"3/8 Z6
Para D=1"3/4 o Z20- Z21
indicar en el pedido

EQUIPAMENTO DE SÉRIE

- Rotor de martelo eletronicamente balanceado.
- Engate fixo centrado CAT II-III.
- Multiplicador altamente robusto.
- Chassis altamente resistente ao desgaste.
- Defletor traseiro para canalizar a entrada de material trabalhando para trás.
- Juntas sem pontos de graxa, com buchas autolubrificantes.
- Rotor suportado por rolamentos oscilantes de longa duração.
- 2 fileiras de contra-martelos removíveis aparafusados em "U".
- Almofadas antidesgaste ajustáveis.
- Porta traseira hidráulica com dois pistões.
- Transmissão lateral dupla por correias dentadas tipo C.
- Martelos especiais com rotação de 360°.
- Proteções dianteiras e traseiras com correntes.
- Parafusos e cardan.
- Preparado para tomadas de força de trator de 1000 rpm.
- Proteção para evitar acidentes de acordo com as normas CE.
- Nota: se especificado no pedido, o multiplicador pode ser preparado para tomadas de força de 540 rpm.

ACESSÓRIOS

Kit 3º ponto hidráulico para sistema de alinhamento do grupo



Kit sistema de alinhamento do grupo

Kit 2 tiras intercambiáveis de contra-martelos em Hardox

Kit de linha suplementar de batentes de porta no Hardox

Barra de proteção traseira fixa

Barra de proteção traseira hidráulica

Kit de embraiagem hidrodinâmico

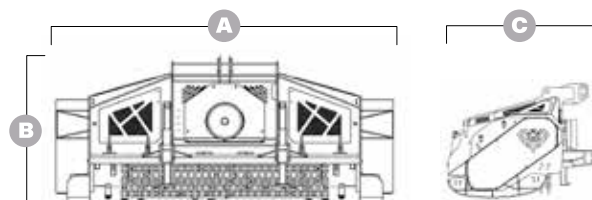

TF200

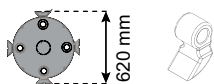

EQUIPAMENTO DE SÉRIE



- Rotor de martelo eletronicamente balanceado.
- Engate fixo centrado CAT III.
- Grupo multiplicador altamente robusto com roda livre.
- Chassis altamente resistente ao desgaste.
- Rotor suportado por rolamentos oscilantes de longa duração.
- 3 fileiras de contra-martelos.
- Polias com cubo cônico removível.
- Almofadas anti desgaste ajustáveis.
- Porta traseira hidráulica com pistão duplo.
- Transmissão lateral por correias dentadas tipo C no modelo TF200/180.
- Transmissão lateral dupla por correias dentadas tipo C nos modelos TF200/200 e TF200/220.
- Martelos especiais com rotação de 360°.
- Proteções dianteiras e traseiras com correntes.
- Parafusos e cardan.
- Preparado para tomadas de força de trator de 1000 rpm.
- Proteção para evitar acidentes de acordo com as normas CE.

ACESSÓRIOS

Kit 3º ponto hidráulico para sistema alinhamento do grupo



Kit sistema de alinhamento do grupo

Barra de proteção traseira fixa

Barra de proteção traseira hidráulica

Suplemento barra traseira com sistema de parafusos desmontável

MOD.

TF200/180

TF200/200

TF200/220

Triturador destinado a um uso florestal pelas suas características de grande robustez em todos os detalhes da máquina.



MOD.	MM	KG	Nº	C.V	Ø	R.PM	Nº	MM	MM	MM
TF200/180	1800	2450	28	120-140	35	1000	5	2450	1615	1330
TF200/200	2000	2560	32	140-160	35	1000	4+4	2650	1615	1330
TF200/220	2200	2680	36	160-200	35	1000	4+4	2850	1615	1330

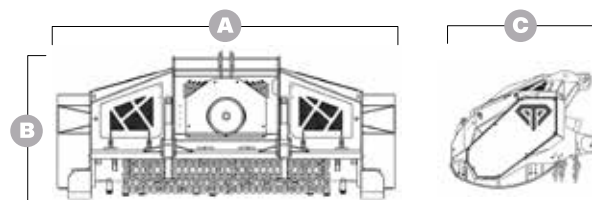
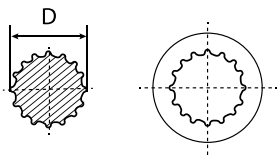

De serie cardan 1"3/4 Z6 - 1"3/4 Z6
Para D=1"3/8 o Z20- Z21
indicar no pedido.

TF175



MOD.

TF175/180

TF175/200

TF175/220

Triturador destinado ao uso florestal devido às suas características de grande robustez em todos os detalhes da máquina.

Kit patins com placa inferior em Hardox

Suplemento barra traseira com sistema de parafusos desmontável



MOD.	MM	KG	Nº	C.V	Ø	R.PM	Nº	MM	MM	MM
TF175/180	1800	1700	33	120-175	30	1000	4+4	2360	1480	1175
TF175/200	2000	1850	39	120-175	30	1000	4+4	2560	1480	1175
TF175/220	2200	2000	45	120-175	30	1000	4+4	2760	1480	1175

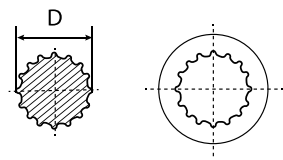

De serie cardan 1"3/8 Z6 - 1"3/8 Z6.
Para D=1"3/4 o Z20- Z21
indicar no pedido

EQUIPAMENTO DE SÉRIE

- Rotor de martelos com pontas fixas em ponta de vidia.
- Engate fixo centrado CAT II-III.
- Multiplicador altamente robusto.
- Chassis altamente resistente ao desgaste.
- Defletor traseiro para canalizar a entrada de material trabalhando para trás.
- Juntas sem pontos de graxa, com buchas auto lubrificantes.
- Rotor suportado por rolamentos oscilantes de longa duração.
- 2 fileiras de contra-martelos removíveis aparafusados em "U"
- Almofadas anti desgaste ajustáveis.
- Porta traseira hidráulica com dois cilindros.
- Transmissão lateral dupla por correias C dentadas
- Proteções dianteiras e traseiras com correntes
- Parafusos e cardan
- Preparado para TDFs de tratores de 1000 rpm
- Proteção para evitar acidentes de acordo com os regulamentos CE
- Nota: se especificado no pedido, o multiplicador pode ser preparado para tomadas de força de 540 rpm.

ACESSÓRIOS

Kit 3º ponto hidráulico para sistema alinhamento do grupo



Kit sistema de alinhamento do grupo

Kit 2 tiras intercambiáveis de contra martelos em Hardox

Kit de linha suplementar de contra martelos em porta em Hardox

Barra de proteção traseira fixa

Barra de proteção traseira hidráulica

Kit de embraiagem hidrodinâmica

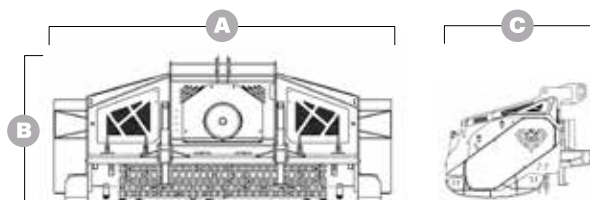

TF250



EQUIPAMENTO DE SÉRIE

- Rotor de martelos com pontas fixas em ponta de vidia.
- Engate fixo centrado CAT III.
- Grupo multiplicador altamente robusto com roda livre.
- Chassis altamente resistente ao desgaste.
- Defletor traseiro para canalizar a entrada de material trabalhando para trás.
- Juntas sem pontos de graxa, com buchas auto lubrificantes.
- Rotor suportado por rolamentos oscilantes de longa duração.
- 3 fileiras de contra-martelos.
- Polias com cubo cônico removível.
- Almofadas anti desgaste ajustáveis.
- Porta traseira hidráulica com pistão duplo.
- Transmissão lateral dupla por correias dentadas tipo C em todos os modelos.
- Proteções dianteiras e traseiras com correntes.
- Parafusos e cardan.
- Preparado para tomadas de força de trator de 1000 rpm.
- Proteção para evitar acidentes de acordo com as normas CE.

ACESSÓRIOS

Kit 3º ponto hidráulico para sistema de alinhamento do grupo

Kit sistema de alinhamento do grupo



Barra de proteção traseira fixa

Barra de proteção traseira hidráulica

Kit de embraiagem hidrodinâmico

Kit 3 tiras intercambiáveis de contra martelos em Hardox

Kit pontas rotor desmontáveis aparafusadas

MOD.

TF250/200

TF250/220

TF250/250

Triturador destinado ao uso florestal devido às suas características de grande robustez em todos os detalhes da máquina.

Suplemento barra traseira com sistema de parafusos desmontável



MOD.	MM	KG	Nº	C.V	Ø	R.PM	Nº	MM	MM	MM
TF250/200	2000	2400	39	175-200	35	1000	5+5	2450	1615	1330
TF250/220	2200	2520	45	175-250	35	1000	5+5	2650	1615	1330
TF250/250	2500	2900	51	200-250	35	1000	5+5	2850	1615	1330

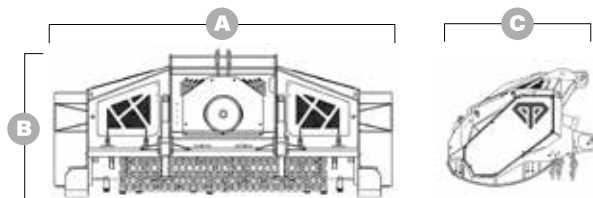
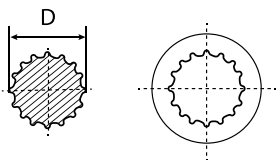

De serie cardan 1"3/4 Z6

TF300

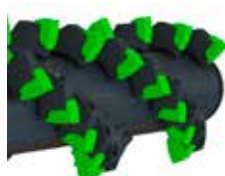

MOD.

TF300/200

TF300/220

TF300/250

Triturador destinado ao uso florestal devido às suas características de grande robustez em todos os detalhes da máquina.

EQUIPAMENTO DE SÉRIE

- Rotor de martelo de 30 mm de espessura com pontas fixas com ponta de vidia.
- Rotor com pavios removíveis para melhor manutenção e melhor aproveitamento.
- Rotor com 4 filas de martelos helicoidais.
- Engate fixo centrado CAT III.
- Grupo multiplicador altamente robusto com roda livre.
- Chassis altamente resistente ao desgaste.
- Rotor suportado por rolamentos oscilantes de alta durabilidade modelo 22318.
- 3 fileiras de contra-martelos intercambiáveis.
- Polias com cubo cônico removível.
- Almofadas anti desgaste ajustáveis.
- Porta traseira hidráulica com pistão duplo.
- Transmissão lateral dupla por correias dentadas tipo C em todos os modelos.
- Proteções dianteiras e traseiras com dupla fileira de correntes.
- Parafusos e cardan.
- Preparado para tomadas de força de trator de 1000 rpm.
- Proteção para evitar acidentes de acordo com as normas CE.

ACESSÓRIOS

Kit 3º ponto hidráulico para sistema de alinhamento do grupo



Kit sistema de alinhamento do grupo

Barra de proteção traseira fixa

Barra de proteção traseira hidráulica

Kit de embraiagem hidrodinâmico para Super Diamond

Suplemento barra traseira com sistema de parafusos desmontável



MOD.	MM	KG	Nº	C.V	Ø	R.PM	Nº	MM	MM	MM
TF300/200	2000	3580	68	250-300	40	1000	6+6	2490	1840	1350
TF300/220	2200	3800	76	250-300	40	1000	6+6	2690	1840	1350
TF300/250	2500	4050	88	250-300	40	1000	6+6	2990	1840	1350

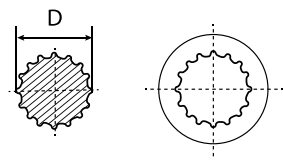

De serie cardan 1"3/4 Z20

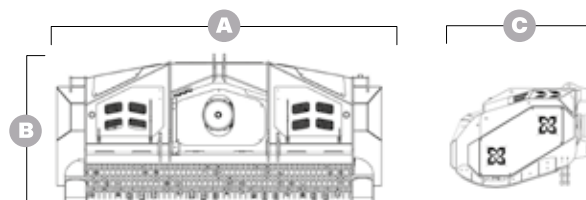

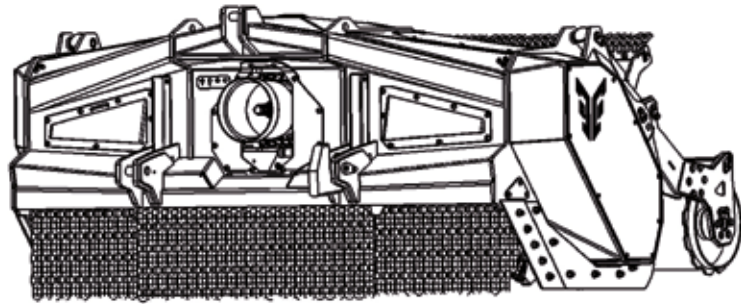

FRESADORES FLORESTAIS

FF300



MOD.

FF300/200

FF300/220

FF300/250

Fresador florestal destinada ao uso tanto em trabalhos profundos (250-300mm) como em trabalhos de trituração florestal.

EQUIPAMENTO DE SÉRIE

- Engate fixo centrado CAT III.
- Grupo multiplicador especial com radiador de refrigeração a óleo.
- Chassi interno coberto com placas Hardox intercambiáveis.
- Rotor com pontas removíveis.
- Patins Hardox profundos.
- Chassi equipado com lâminas frontais de penetração no solo intercambiáveis em Hardox.
- Suporte de martelo Hardox com geometria de cunha especial para melhor trabalho no modo de fresagem.
- Martelos exclusivos com design especial para profundidade.
- Proteção de alça estreita para melhorar a profundidade com armadura Hardox.
- Sistema de transmissão dupla com 2 correias Polychain de alto desempenho.
- 3 tiras de contra-martelos em Hardox.
- Juntas sem pontos de graxa, com buchas autolubrificantes.
- Cardan com limitador de torque e parafusos.
- Proteção para evitar acidentes de acordo com as normas CE.

ACESSÓRIOS

Kit 3º ponto hidráulico para sistema de alinhamento do grupo



Kit sistema de alinhamento do grupo

Suplemento de flange largo de controle de profundidade sanduíche com placa inferior Hardox

Rolo traseiro liso com anéis de serra de controle de profundidade



MOD.	MM	KG	Nº	C.V	Ø	MM PROFUNDIDAD	R.PM	Nº	MM	MM	MM
FF300/200	2000	3850	48	200-300	40	250-300	1000	2	2350	2221	1276
FF300/220	2200	4000	54	200-300	40	250-300	1000	2	2550	2221	1276
FF300/250	2500	4200	63	200-300	40	250-300	1000	2	2890	2221	1276

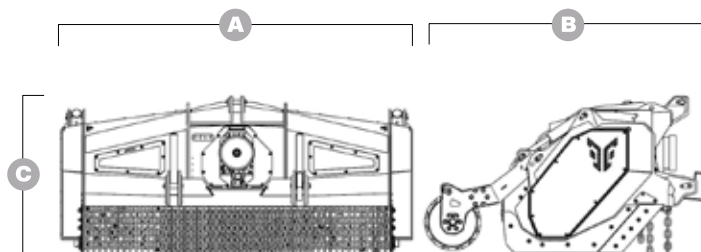
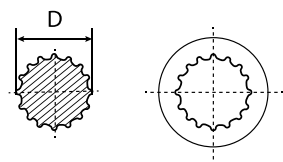

De serie cardan 1"3/4 Z20

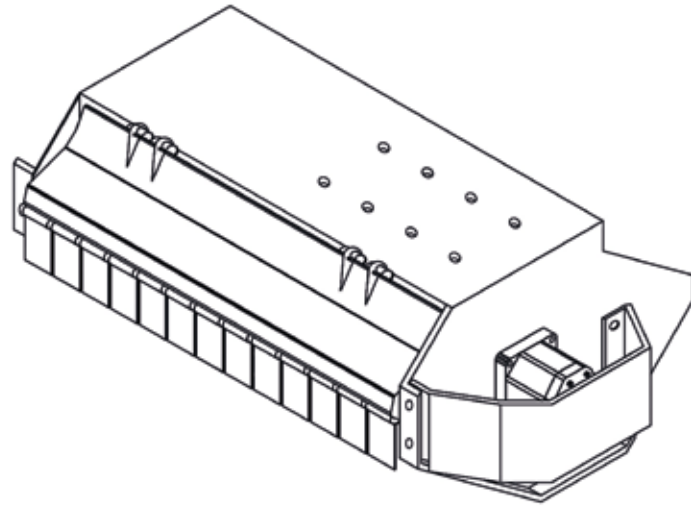

BRAÇOS DESTROÇADORES

BD35**ACESSÓRIOS**

BD010
Cardan

BD012
Permutador de calor

BD011
Tensores de regulação

BD041
Suporte engate tensores ao trator

BD040
Comando joystick manual com cabos

BD013
Comandos eletrónicos joystick (roller)

BD039
Comandos elétricos proporcionais (joystick)

COD.7006
Erva e madeira max. 3 cm

de serie

**MOD.**

BD35/170

BD35/250

BD35/300

BD35/350

Destroçadores hidráulicos para micro-tractores com potência de 13 a 35 cavalos, desenhado para a limpeza em fossas, em estradas e aterros e em parques.



+info pág. 60

Indicar no pedido a montagem da máquina – de serie é com a figura 2D:

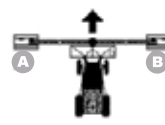

Fig. 1

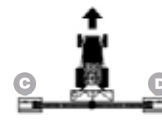

Fig. 2

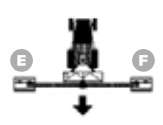

Fig. 3

EQUIPAMENTO DE SÉRIE

- Comandos à distância teleflexíveis (2000 mm).
- Instalação hidráulica independente.
- Sistema mecânico anti-choque.
- Rolo traseiro ajustável em altura.
- Transmissão por correias no modelo BZE170.
- Transmissão direta nos demais modelos.
- Adaptação da cabeça ao solo.
- Rotação reversível do rotor.
- Proteções para evitar acidentes de acordo com as normas CE.



MOD.	KG	R.P.M.	LT	KG	C.V.	CM
BD35/170	220	540	35	550	13/25	100
BD35/250	260	540	48	700	20/30	100
BD35/300	310	540	55	800	20/30	120
BD35/350	350	540	55	900	23/35	120

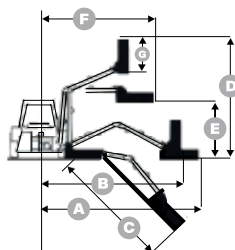

	A	B	C	D	E	F	G
MOD.	MM	MM	MM	MM	MM	MM	MM
BD35/170	1700	1850	900	2300	1150	1150	500
BD35/250	2500	2400	2000	2800	1600	1700	600
BD35/300	3000	2900	2500	3300	1800	1900	800
BD35/350	3500	3400	3000	3500	2000	2100	800

BD70**MOD.**

BD70/350

BD70/400

BD70/450

Destroçadores hidráulicos para tratores de 40 a 70 CV, ideal para a limpeza de fossa, valas e beiras de estradas.

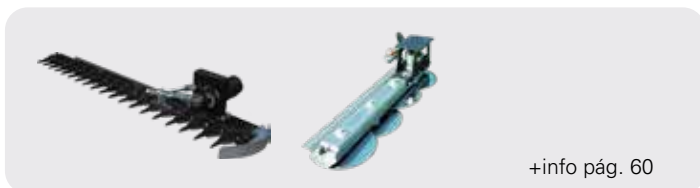

Indicar no pedido a montagem na máquina – de serie é como a figura 2D:

ACESSÓRIOS

BAC014
Dispositivo anti-golpe hidráulico

BD015
Transmissão por correias

BD016
Tensores de regulação

BD041
Suporte de engate dos tensores ao trator

BD040
Comando joystick manual com cabos

BD018
Comandos electrónicos joystick (roller)

BD037
Comandos eléctricos proporcionais (joystick)

BD017
Permutador de calor

COD.7001
Erva e madeira max. 3 cm

de serie



BD001
Erva e madeira max. 4 cm - COD.7002

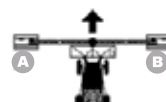

Fig. 1



Fig. 2



Fig. 3

EQUIPAMENTO DE SÉRIE

- Comandos à distância teleflexíveis (2500 mm).
- Instalação hidráulica independente.
- Sistema mecânico anti-choque.
- Rolo traseiro ajustável em altura.
- Transmissão direta em todos os modelos.
- Adaptação da cabeça ao solo.
- Bar com luzes.
- Patins.
- Cardan.
- Rotação reversível do rotor.
- Proteções para evitar acidentes de acordo com as normas CE.



MOD.	KG	R.P.M.	LT	KG	C.V.	CM
BD70/350	470	540	85	1800	40/50	150
BD70/400	530	540	85	2100	50/60	160
BD70/450	570	540	85	2200	50/70	160

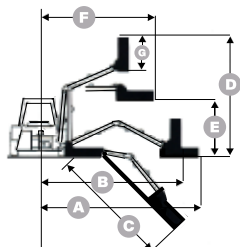

	A	B	C	D	E	F	G
MOD.	MM	MM	MM	MM	MM	MM	MM
BD70/350	3600	3000	2900	4400	2300	2000	800
BD70/400	4200	3400	3300	4800	2600	2300	1000
BD70/450	4700	3900	3500	5000	2900	2500	1000

BD70**MOD.**

BD70/415

BD70/470

Destroçadores hidráulicos para tratores de 50 a 70 CV, ideais para a limpeza de ervas daninhas em plantações de treliças, como vinhas, limpeza de bordas de cercas de estradas, etc.



+info pág. 60

Indicar no pedido a montagem na máquina – de serie é como a figura 2D:

ACESSÓRIOS**BD016**

Tensores de regulação

BD041

Suporte de engate dos tensores ao trator

BD040

Comando joystick manual com cabos

BD063

Comandos electrónicos joystick (roller)

BD064

Comandos eléctricos proporcionais (joystick)

BD017

Permutador de calor

COD.7001

Erva e madeira max. 3 cm

de serie

**BD001**

Erva e madeira max. 4 cm - COD.7002

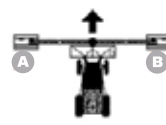

Fig. 1

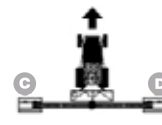

Fig. 2

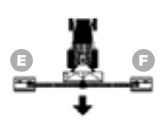

Fig. 3

EQUIPAMENTO DE SÉRIE

- Comandos à distância teleflexíveis (2500 mm).
- Instalação hidráulica independente.
- Sistema hidráulico anti-choque.
- Rolo traseiro ajustável em altura.
- Transmissão direta em todos os modelos.
- Adaptação da cabeça ao solo.
- Bar com luzes.
- Patins.
- Cardan.
- Rotação reversível do rotor.
- Proteções para evitar acidentes de acordo com as normas CE.



MOD.	KG	R.P.M.	LT	KG	C.V.	CM
BD70/415	530	540	95	2200	50-70	160
BD70/470	530	540	95	2200	50-70	160

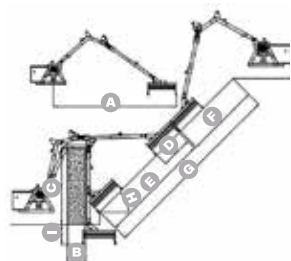

	A	B	C	D	E	F	G	H	I
MOD.	MM	MM	MM	MM	MM	MM	MM	°	MM
BD70/415	4150	600	2200	800	3200	2170	5370	45°	300
BD70/470	4700	600	2500	800	3800	2500	6300	45°	370

BD90**MOD.**

BD90/400

BD90/450

BD90/485

BD90/500

BD90/530

BD90/570

Destroçadores hidráulicos para tratores de média potência de 50 a 90 CV, ideais para limpeza de fossas, valas e bordas de vias públicas.



+info pág. 60

Indicar no pedido a montagem na máquina – de serie é como a figura 2D:

ACESSÓRIOS

BD019
Transmissão por correias

BD020
Permutador de calor

BD060
Acumulador de azoto no primeiro braço

BD041
Suporte de engate dos tensores ao trator

BD040
Comando joystick manual com cabos

BD021
Comandos electrónicos joystick (roller)

BD058
Comandos eléctricos proporcionais (joystick)

COD.7003
Erva e madeira max. 6 cm

de serie



BD002
Erva e madeira max 3 cm - COD.7001



BD003
Erva e madeira max. 4 cm - COD.7002

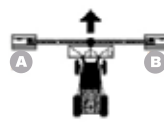

Fig. 1

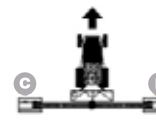

Fig. 2

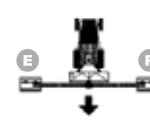

Fig. 3

EQUIPAMENTO DE SÉRIE

- Comandos à distância teleflexíveis (3000 mm).
- Instalação hidráulica independente.
- Sistema hidráulico anti-choque.
- Rolo traseiro ajustável em altura.
- Transmissão direta em todos os modelos.
- Adaptação da cabeça ao solo.
- Bar com luzes.
- Patins.
- Cardan.
- Tensores de regulação.
- Rotação reversível do rotor.
- Proteções para evitar acidentes de acordo com as normas CE



MOD.	KG	R.P.M.	LT	KG	C.V.	CM
BD90/400	780	540	190	2000	50/60	160
BD90/450	820	540	190	2500	60/70	160
BD90/485	850	540	200	2800	60/80	170
BD90/500	860	540	200	2800	60/80	170
BD90/530	870	540	200	3000	70/90	180
BD90/570	895	540	200	3200	80/90	200

A

B

C

D

E

F

G

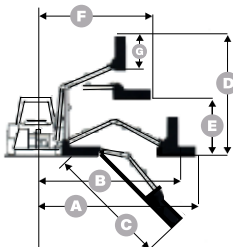

MOD.	MM	MM	MM	MM	MM	MM	MM
BD90/400	4000	3700	2900	3800	2100	1500	1000
BD90/450	4500	4200	3400	4300	2350	1700	1000
BD90/485	4850	4500	3750	4650	2500	1800	1000
BD90/500	5000	4700	3900	4800	2600	1900	1000
BD90/530	5300	5000	4200	5100	2750	2050	1000
BD90/570	5700	4300	4600	5400	2900	2250	1000

BD100**MOD.**

BD100/500

BD100/550

BD100/600

Destroçadores hidráulicos para tratores de média potência de 80 a 110 CV, ideais para limpeza de fossas, valas e bordas de vias públicas.



+info pág. 60

ACESSÓRIOS

BD060
Acumulador de azoto no primeiro braço

BD022
Acumulador de azoto no braço de rotação

ACESSÓRIOS

BD024
Transmissão por correias

BD025
Kit bomba e motor em fundição (60 CV)

BD026
Permutador de calor

BD038
Rotação adicional do destroçador em 90°

BD027
Comandos electrónicos joystick (roller)

BD042
Comandos elétricos proporcionais (joystick)

BD041
Suporte de engate dos tensores ao trator

COD.7003
Erva e madeira max. 6 cm

de serie



BD004
Erva e madeira max 3 cm - COD.7001



BD005
Erva e madeira max. 4 cm - COD.7002



BD006
Erva e madeira max 8 cm - COD.7004



BD007
Erva e madeira max 4 cm - COD.7012



BD008
Erva e madeira max 4 cm - COD.7014



BD009
Erva e madeira max 4 cm - COD.7011



BAC044
Erva e madeira máx 6 cm – COD.7016



EQUIPAMENTO DE SÉRIE

- Comandos à distância teleflexíveis (3000 mm).
- Instalação hidráulica independente.
- Sistema hidráulico anti-choque.
- Rolo traseiro ajustável em altura.
- Transmissão direta em todos os modelos.
- Adaptação da cabeça ao solo.
- Bar com luzes.
- Patins.
- Cardan.
- Tensores de regulação.
- Rotação de segurança hidráulica 90°.
- Rotação reversível do rotor.
- Proteções para evitar acidentes de acordo com as normas CE.



MOD.	KG	R.P.M.	LT	KG	C.V.	CM
BD100/500	1120	540	200	3700	80/100	200
BD100/550	1170	540	200	3900	90/100	200
BD100/600	1210	540	205	4300	90/110	210

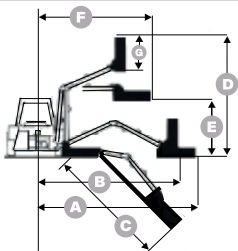

	A	B	C	D	E	F	G
MOD.	MM	MM	MM	MM	MM	MM	MM
BD100/500	5000	4200	3900	4900	2300	1900	1000
BD100/550	5500	4700	4300	5400	2600	2100	1000
BD100/600	6000	5500	4800	5900	2800	2500	1200

Indicar no pedido a montagem na máquina – de série é como a figura 2D:

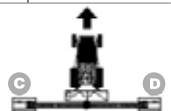
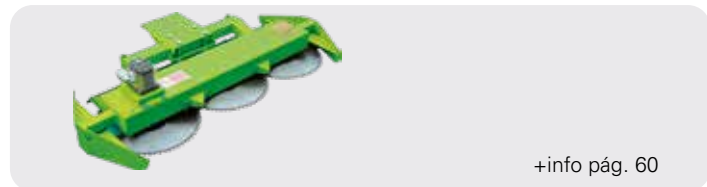

Fig. 2

BD140**MOD.****BD140/660**

Destroçador hidráulico profissional, para tratores de 100 a 140 CV, ideal para limpeza de fossas, valas e bordas de vias públicas.



+info pág. 60

ACESSÓRIOS

BD060
Acumulador de azoto no primeiro braço

BD022
Acumulador de azoto no braço de rotação

ACESSÓRIOS

BD029
Transmissão por correias

BD041
Suporte de engate dos tensores ao trator

BD038
Rotação adicional do destroçador em 90°

BD030
Comandos electrónicos joystick (roller)

BD036
Comandos elétricos proporcionais (joystick)

COD.7003
Erva e madeira max. 6 cm



de serie

BD004
Erva e madeira max 3 cm - COD.7001



BD005
Erva e madeira max. 4 cm - COD.7002



BD006
Erva e madeira max 8 cm - COD.7004



BD007
Erva e madeira max 4 cm - COD.7012



BD008
Erva e madeira max 4 cm - COD.7014



BD009
Erva e madeira max 4 cm - COD.7011



BD044
Erva e madeira max 6 cm - COD.7016



EQUIPAMENTO DE SÉRIE

- Comandos à distância teleflexíveis (3000 mm).
- Instalação hidráulica independente.
- Sistema hidráulico anti-choque.
- Rolo traseiro ajustável em altura.
- Transmissão direta em todos os modelos.
- Adaptação da cabeça ao solo.
- Bar com luzes.
- Kit bomba e motor em ferro fundido (60 CV).
- Patins.
- Cardan.
- Tensores de regulação.
- Trocador de calor.
- Rotação de segurança hidráulica 90°.
- Cabeça telescópica.
- Rotação reversível do rotor.
- Proteções para evitar acidentes de acordo com as normas CE.



MOD.	KG	R.P.M.	LT	KG	C.V.	CM
BD140/660	1320	540	215	4500	100/140	210

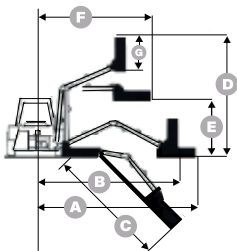

MOD.	MM	MM	MM	MM	MM	MM	MM
BD140/660	6600	5900	5400	6800	2700	2500	1200

Indicar no pedido a montagem na máquina – de série é como a figura 2D:



Fig. 2

ACESSÓRIOS INTERCAMBIÁVEIS

BD35 - BD70



BD074
Barra de corte para arbustos



MOD.	MM	KG	CM MAX	L/MIN	BAR
BD074-120	1200	50	1	35-45	120-170
BD074-150	1500	60	1	35-45	120-170



BD083
Barra de discos Ø400



MOD.	MM	Nº ☀	KG	CM MAX	L/MIN	BAR
BD083-3	1050	3	40	6	40-50	150-170
BD083-4	1400	4	50	6	40-50	150-170

BD90



BD076
Barra de corte para arbustos



MOD.	MM	KG	CM MAX	L/MIN	BAR
BD076-120	1200	50	1	35-45	120-170
BD076-150	1500	60	1	35-45	120-170

BD90 - BD100 - BD140



BD082
Barra de discos Ø600



MOD.	MM	Nº ☀	KG	CM MAX	L/MIN	BAR
BD082-3	1650	3	160	8	90-100	150-170
BD082-4	2200	4	200	8	90-100	150-170

+ INFO**BD35**

MOD.	COD.7006
BD35/170	28
BD35/250	28
BD35/300	40
BD35/350	40

BD70

MOD.	COD.7001	COD.7002
BD70/350	28	28+14
BD70/400	36	36+18
BD70/450	36	36+18

BD70

MOD.	COD.7001	COD.7002
BD70/415	28	28+14
BD70/470	28	28+14

BD90

MOD.	COD.7001	COD.7002	COD.7003
BD90/400	36	36+18	32+16
BD90/450	36	36+18	32+16
BD90/485	36	36+18	32+16
BD90/500	36	36+18	32+16
BD90/530	36	36+18	32+16
BD90/570	36	36+18	32+16

BMG









MOD.	COD.7001	COD.7002	COD.7003	COD.7004	COD.7011	COD.7012	COD.7014
BD100/500	36	36+18	32+16	28+14	44	12	22
BD100/550	36	36+18	32+16	28+14	44	12	22
BD100/600	44	44+22	40+20	32+16	52	14	26

BMT

MOD.	COD.7001	COD.7002	COD.7003	COD.7004	COD.7011	COD.7012	COD.7014
BD140/660	44	44+22	40+20	32+16	52	14	26

FERRAMENTAS DE CORTE

MARTELOS

	REF.	MOD.	
	TF725	TF120 TF160	
	TF008	TF200	
	TF330	TF120 TF175 TF250 TF300	
	DH329	DH-3 DH-5.5 DH-8	
	DH328 DHC328	DH-9 DHCL-120	
	DH725 DHC725	DHL-16 DHO-13 DHL-20 DHCL-120	
	DH008	DHL-30	
	DH330 DHC330	DHF-13 DHF-16 DHF-20 DHF-30 DHCF-120	

WWW.STETFLORESTAL.PT

STET
FLORESTAL

Rua da Guiné
2685-334 Prior Velho
LISBOA

 /STETFlorestal/

 /company/stet-florestal/

 800 206 707